

BRIZO®

BATHROOM FAUCETS

- Vettis® Bath Collection
- Two Handle Wall-Mount

STANDARD SPECIFICATIONS:

- Max flow rate 1.2 gpm @ 60 psi, 4.5 L/min @ 414 kPa
- Three-hole mount
- Control mechanism is a rotating cylinder ceramic cartridge with 90° rotation
- Rough-in R65800 required for installation, not included
- Drain sold separately

WARRANTY

- Parts and Finish - Lifetime limited warranty; or for commercial purchasers, 10 years for multi-family residential (apartments and condominiums) and 5 years for all other commercial uses, in each case from the date the product is received by the original purchaser or their authorized representative (installation contractor, etc.).
- Electronic Parts and Batteries (if applicable) - 5 years from the date the product is received by the original purchaser or their authorized representative (installation contractor, etc.); or for commercial purchasers, 1 year from the date the product is received by the original purchaser or their authorized representative (installation contractor, etc.). No warranty is provided on batteries.
- Please go to www.brizo.com for the complete details of our limited warranty.



COMPLIES WITH:

- ASME A112.18.1 / CSA B125.1
- ASME A112.18.2 / CSA B125.2
- EPA WaterSense®
- ♿ ICC/ANSI A117.1 - Valve control only

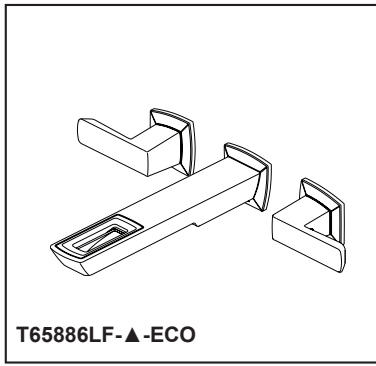

T65886LF-▲-ECO

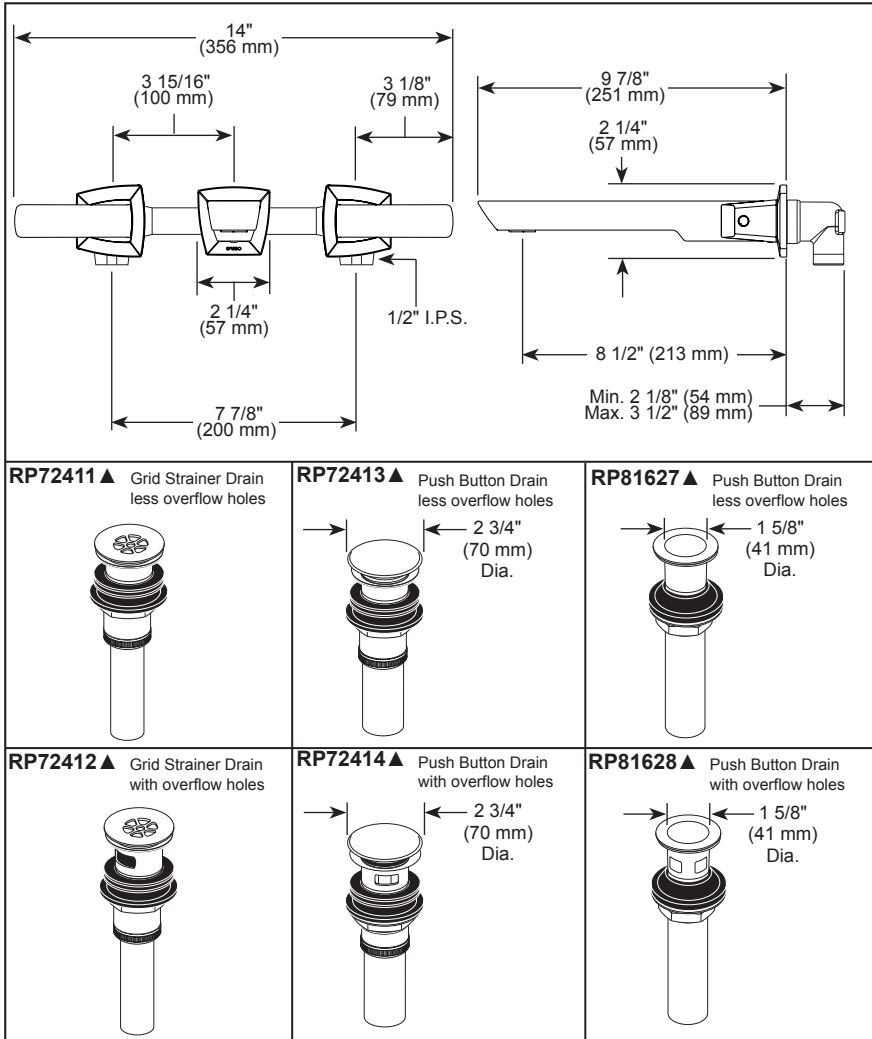

▲ Designate Proper Finish Suffix